

# 72" CAMBRIDGE STRUT AND P-LAM SHELVING KIT

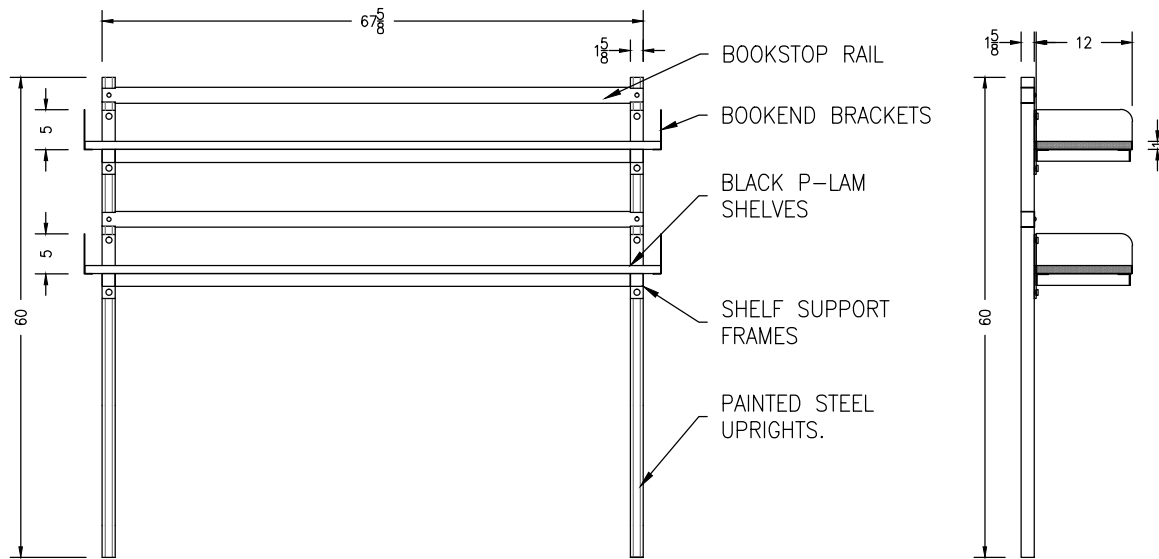

- ADJUSTMENT: SHELVING BRACKETS ARE ADJUSTABLE IN HEIGHT ALONG 1 5/8"x1 5/8" STRUT WHICH RISES 45" ABOVE THE WORKSURFACE.
- SHELVING: 1" PARTICLEBOARD CORE WITH HORIZONTAL GRADE PLASTIC LAMINATE ON BOTH SIDES AND BANDED WITH DURABLE 3MM BLACK PVC EDGE.
- FLEXIBILITY: ADD/ REMOVE/ ADJUST HEIGHT ON ANY STANDARD CAMBRIDGE SERIES TABLE.
- WEIGHT CAPACITY: SUPPORTS 200LB PER SHELF
- COLOR: WARM GRAY FRAME WITH BLACK SHELVES
- ALL BOLTING HARDWARE INCLUDED

INCLUDED IN SHELVING KIT		
QTY	DISCRIPTION	COLOR
2	60" 11 GA PAINTED STEEL STRUT UPRIGHTS	WARM GRAY
2	11 + 16 GA SHELF SUPPORT FRAMES	WARM GRAY
2	14 GA BOOKSTOP RAILS	WARM GRAY
2	1" PLASTIC LAMINATE SHELVES	BLACK
4	18 GA BOOKEND BRACKETS	WARM GRAY



**NEL direct**  
 online industrial & laboratory furniture  
 888.635.2949 | [NELdirect.com](http://NELdirect.com)

TOSK72

09/03/15

# 30"X72" CAMBRIDGE Q SERIES LAB TABLE WITH 1" BLACK EPOXY TOP

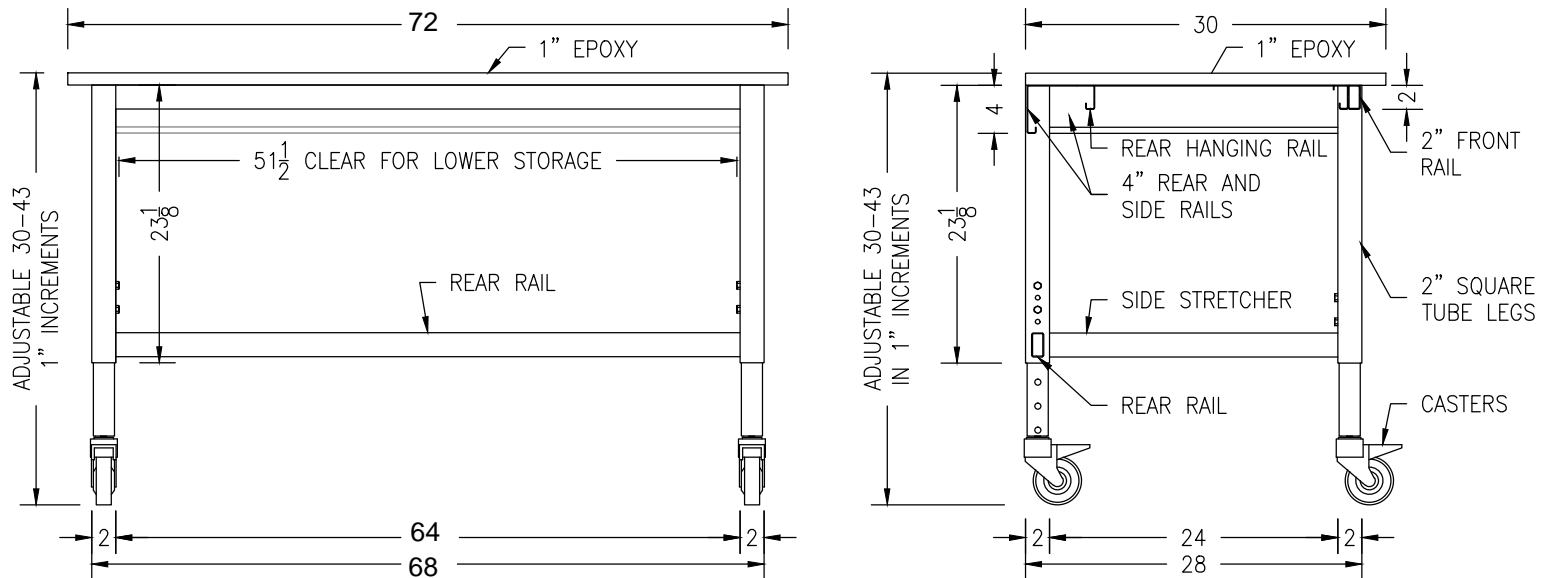

\*LEVELING FEET SHIPPED LOOSE FOR FUTURE USE



- CONSTRUCTION: PANTED STEEL FULLY WELDED FRAME WITH STAINLESS STEEL DUAL BOLTED LEG INSERTS FOR ADJUSTMENT
- ADJUSTMENT: TABLES ADJUST IN 1" INCREMENTS
  - LEVELING FEET: 25-38" INCLUDING 1" COUNTERTOP
  - CASTERS: 30-43" INCLUDING 1" COUNTERTOP
- MOBILITY: BOTH LEVELING FEET AND CASTERS ARE INCLUDED
- LOWER STORAGE FLEXIBILITY: HANGING RAILS SUPPORT UNDER WORKSURFACE COMPONENTS (SOLD SEPARATELY)
- UPPER FLEXIBILITY: OPTIONAL SHELVING SYSTEM (SOLD SEPARATELY) BOLTS TO REAR TABLE LEGS (ADDING 1.625" DEPTH)
- WEIGHT CAPACITY: 1000 LBS EVENLY DISTRIBUTED ON FRAME FOR SUPPORTING THE WORK SURFACE, LOWER STORAGE, AND BENCH TOP EQUIPMENT
- 1" THICK **72"** WIDE X 30" DEEP) BLACK EPOXY WORKSURFACE INCLUDED
- WORKSURFACE HAS A 2" OVERHANG AT THE FRONT AND SIDES AND IS FLUSH WITH THE BACK FOR ADDING FUTURE OVERHEAD ACCESSORIES
- \* CASTER SWIVEL MAY INTERFERE WITH SUSPENDED CABINETS AT LOWER TABLE HEIGHT ADJUSTMENTS



# 30"X72" CAMBRIDGE Q SERIES LAB TABLE WITH 1" BLACK EPOXY TOP

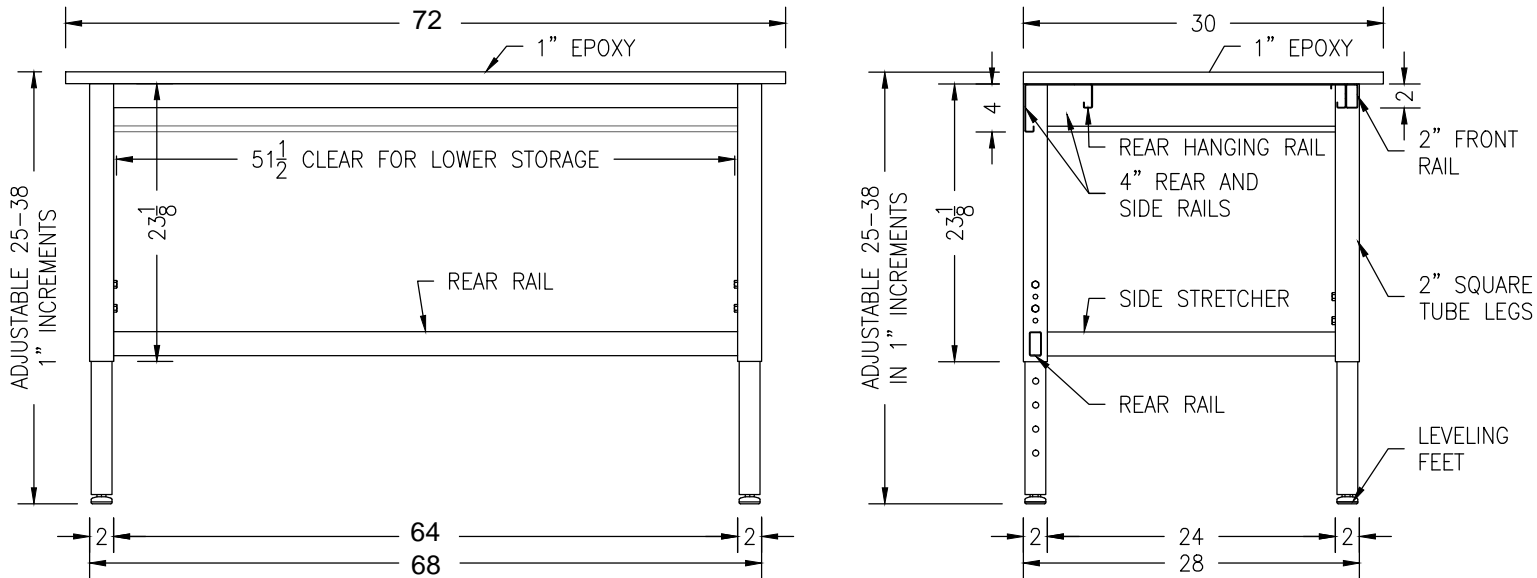

\*CASTERS SHIPPED LOOSE FOR FUTURE USE



- CONSTRUCTION: PAINTED STEEL FULLY WELDED FRAME WITH STAINLESS STEEL DUAL BOLTED LEG INSERTS FOR ADJUSTMENT
- ADJUSTMENT: TABLES ADJUST IN 1" INCREMENTS
  - LEVELING FEET: 25-38" INCLUDING 1" COUNTERTOP
  - CASTERS: 30-43" INCLUDING 1" COUNTERTOP
- MOBILITY: BOTH LEVELING FEET AND CASTERS ARE INCLUDED
- LOWER STORAGE FLEXIBILITY: HANGING RAILS SUPPORT UNDER WORKSURFACE COMPONENTS (SOLD SEPARATELY)
- UPPER FLEXIBILITY: OPTIONAL SHELVING SYSTEM (SOLD SEPARATELY) BOLTS TO REAR TABLE LEGS (ADDING 1.625" DEPTH)
- WEIGHT CAPACITY: 1000 LBS EVENLY DISTRIBUTED ON FRAME FOR SUPPORTING THE WORK SURFACE, LOWER STORAGE, AND BENCH TOP EQUIPMENT
- 1" THICK **72"** WIDE X 30" DEEP) BLACK EPOXY WORKSURFACE INCLUDED
- WORKSURFACE HAS A 2" OVERHANG AT THE FRONT AND SIDES AND IS FLUSH WITH THE BACK FOR ADDING FUTURE OVERHEAD ACCESSORIES
- \* CASTER SWIVEL MAY INTERFERE WITH SUSPENDED CABINETS AT LOWER TABLE HEIGHT ADJUSTMENTS